

Ingenuity EPIC Table

specifications

HPL Tops:

The core material is 1.125" thick particle board with a phenolic backer sheet and high pressure laminate (HPL) on top making the top 1.25" thick. Complimentary thin PVC edge banding is applied to all sides, square corners.

HPL Rails:

The core material is .935" thick particle board with double sided high pressure laminate (HPL) making the top 1.06" thick. 5" height. Railings match the color of the laminate top. WB standard 3mm PVC edge banding* is applied to all sides, square corners.

Railings are attached to the laminate top using joint connector bolts going into threaded inserts making it an extremely strong metal-to-metal connection.

*3mm PVC edge banding is matching, unless otherwise specified. Complementary color available upon request.

Shipping Class: Tops: 70

NMFC#: Tops: 83620-2, Frames: 82790

Assembly: Unassembled

Standard Features:



3" heavy duty locking casters (-HDCA)*

*Casters are NOT to be used as leveling devices and require field assembly. Raises overall heights by 3.5".

EPIC Frame:

The frame is 16-gauge steel and is fully MIG welded together. Frame leg tubes ① are 3" x 2" and tubes ② are 2" x 2". The 10-gauge mounting plate ③ is welded to the tubes and is attached to the table top using joint connector bolts. The frame legs are finished off with a 3" heavy duty locking caster that has a 3/8" x 16 x 1 stem with thread. Casters are NOT to be used as a leveling device and require field assembly.

Crossbar:

The adjustable crossbar consists of an outer 16-gauge tube ④ which is 1" x 2" and an inner 16-gauge tube ⑤ which is 3/4" x 1 3/4". The crossbar is attached to the frame using joint connector bolts and nuts going through a 16-gauge plate ⑥ located on both ends of the crossbar. The crossbar has welded 16-gauge steel tabs ⑦ at preset locations for fastening the crossbar to the back of the table top using #10 square pan screws.

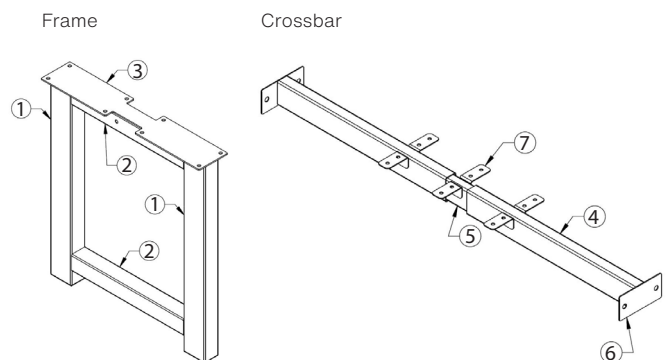

Finish:

The frame comes with a smooth silver or textured black finish. The crossbar is always textured black. Colored frames are optional (blue, green, orange, purple, red).



Additional Colors for EPIC frames



Ingenuity EPIC Table

Model #	Wgt	Description	Top D"x L"	Worksurface H"	Overall H"
EPC3071-FX-RR6	101	Comes Standard w/ Heavy Duty Casters	26.12 x 62.12	29.36	33.11
EPC3071-WFX-RR6	103	Comes Standard w/ Heavy Duty Casters	26.12 x 62.12	36	39.75
EPC3071-SFX-RR6	104	Comes Standard w/ Heavy Duty Casters	26.12 x 62.12	40	43.75
EPC3082-FX-RR6	116	Comes Standard w/ Heavy Duty Casters	32.12 x 62.12	29.36	33.11
EPC3082-WFX-RR6	118	Comes Standard w/ Heavy Duty Casters	32.12 x 62.12	36	39.75
EPC3082-SFX-RR6	119	Comes Standard w/ Heavy Duty Casters	32.12 x 62.12	40	43.75



Optional Features:



1.25" Soft Touch glide (-FG)



1.25" Steel glide (-SG)



2.5" Grand Hank glide (-HG)



Dual wheel soft tread locking casters (-CA)*



3" heavy-duty locking casters (-HDCA)*









Tote tray kit (-TB_)
(Clear is standard. See catalog for color selection.)



3" heavy-duty locking colored casters (-HDCC_)*

3" Heavy Duty Colored Caster Chart

Model #	SKU	Colored Caster
-HDCCP	04067882-P	Purple 
-HDCCR	04067882-R	Red 
-HDCCCL	04067882-L	Lime Green 
-HDCCB	04067882-B	Blue 
-HDCCO	04067882-O	Orange 
-HDCCG4	04067882-G4	Grey 
-HDCC09	04067882-09	Black 

*Casters are NOT to be used as leveling devices and require field assembly. (-CA) raise overall heights by 2.11 and (-HDCA & -HDCC_) raise heights by 3.5".