

Assembly Instructions

Ingenuity EPIC Table



Before you begin, please make sure all parts and proper quantities are included. (See Part Identifier Key) Any parts damaged during shipment must be reported within 24 hours of receipt. To report information regarding damages or if you have any questions, please call 800.242.2303.

Tools Required

- Screw gun
- # S2 square bit
- 4mm hex bit
- 4mm hex wrench
- 3/4" wrench

Step 1:

- Place the EPIC frame leg with plate facing down on a protected flat surface.

Step 2:

- Align holes in the end plate of the cross bar with the frame. Make sure the tabs on the cross bar are facing down.
- Connect cross bar to the frame using 1/4"-20 x 45mm joint connector bolts and 1/4"-20 joint connector nuts.
- Use a screw gun and a 4mm hex bit to tighten the joint connector bolts to the nut. We suggest using a 4mm hex wrench to hold the nut in place while tightening the bolt.
- Repeat for other frame leg.

Step 3:

- Place the top face down on a protected flat surface so threaded inserts and pre-drilled pilot holes are facing up.

Step 4:

- Place frame leg/cross bar on the top and align with threaded inserts & pre-drilled pilot holes.
- Using a screw gun and a 4mm hex bit, secure both frame legs to top with 1/4"-20 x 15mm joint connector bolts. Use (8) bolts for each frame leg.

Step 5:

- Using a screw gun and a # S2 square bit, secure cross bar to top with #10 x 3/4" square pan screws. Use one screw per tab with a total of (6) screws being used (3 per side).

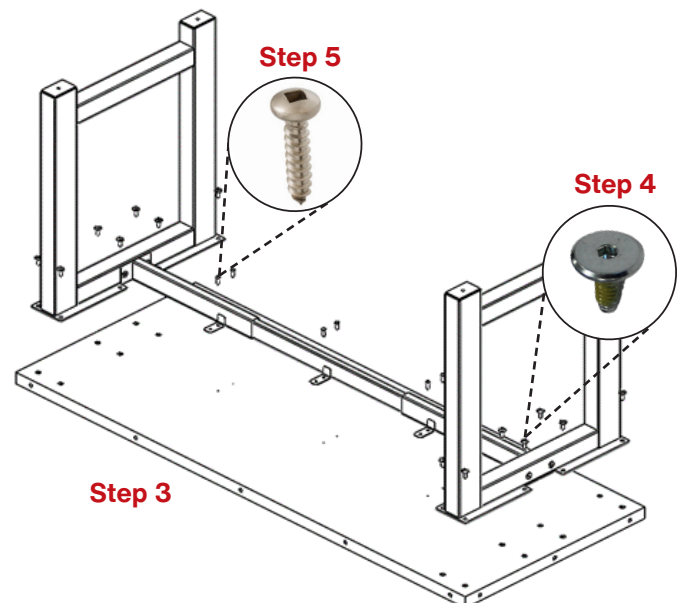
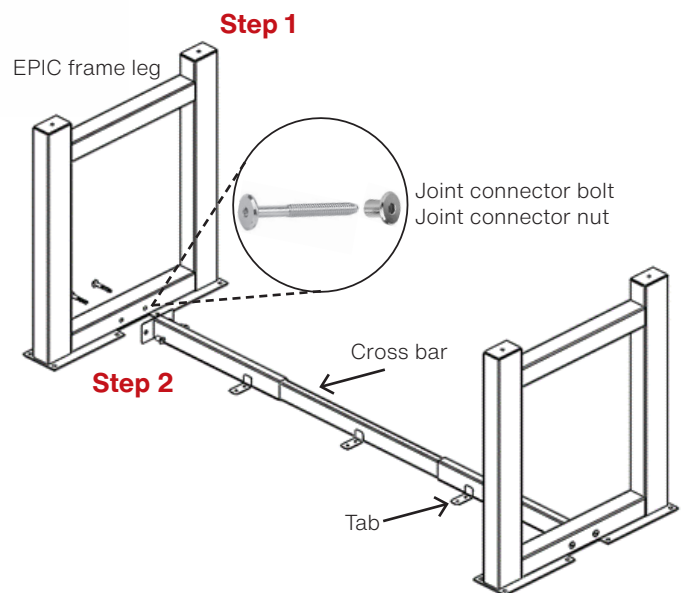

Assembly Instructions

Ingenuity EPIC Table

Step 6:

- Before placing caster in the bottom of the frame leg, lock the caster by pushing down on the brake lever.
- Twist the stem of the caster into the hole on the bottom of the leg frame.
- Use $\frac{3}{4}$ " wrench to tighten $\frac{3}{4}$ " nut on stem of caster.
- Repeat for remaining casters.

Step 7:





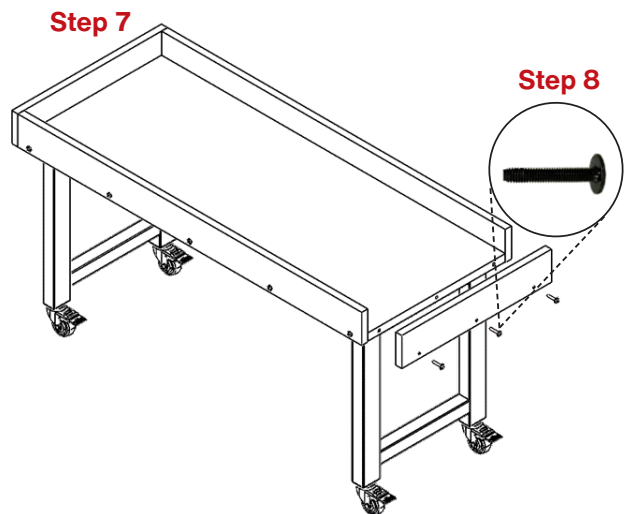
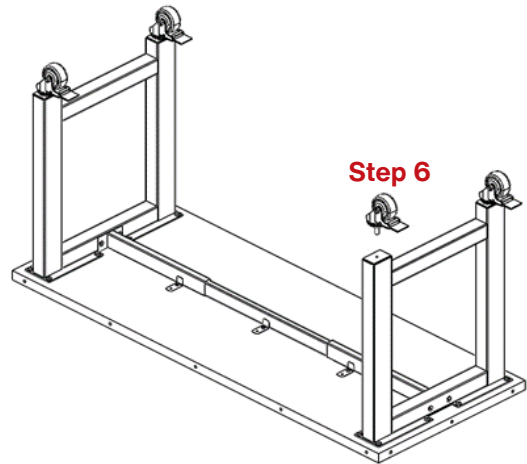

- Turn table to the upright position with the help of another person.

Step 8:

- Align pre-drilled holes in one of the long laminate rails with the threaded inserts in the side of the top.
- Using a $\frac{1}{4}$ "-20x40mm joint connector bolt, insert the bolt through the pre-drilled hole in the rail into the threaded insert of the top. Use a 4mm Allen wrench or a 4mm hex bit and a screw gun to fasten bolt into place.
- After the first bolt is fastened, proceed attaching the remaining bolts in the long rail.
- Repeat **Step 8** for the remaining three rails.



Part Identifier Key

Step #	Part #	Description	Qty.	
Step 2	N/A	1/4"-20 x 45mm joint connector bolts	2 per leg frame (4 total)	
Step 2	04009022	1/4"-20 joint connector nuts	2 per leg frame (4 total)	
Step 4	04009023	1/4"-20 x 15mm joint connector bolts	8 per leg plate (16 total)	
Step 5	0408231	#10 x 3/4" Square pan screw	3 per side of the cross bar (6 total)	
Step 6	0400993	3" heavy duty locking casters	1 per leg (4 total)	
Step 8	0406526	1/4"-20 x 40mm joint connector bolts	16	

EPIC Frame Legs and Adj Cross Bar

Model #	Sku #	EPIC Frame Leg Description
EPC -FX	04067852	EPIC fixed frame leg w/3" heavy duty locking casters
EPC -WFX	04067853	EPIC fixed frame leg w/3" heavy duty locking casters
EPC -SFX	04067854	EPIC fixed frame leg w/3" heavy duty locking casters
04067855	04067855	EPIC Frame Adj. Cross Bar 34"- 64"

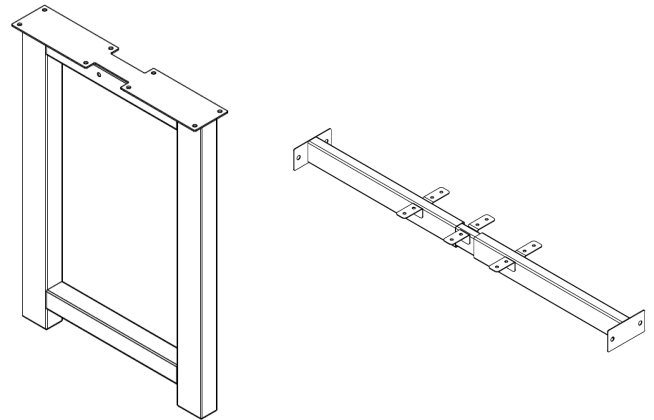

Standard Frame Color



Additional Colors for EPIC frames

