

Assembly Instructions

LOBO Table Laminate/Phenolic



Before you begin, please make sure all parts and proper quantities are included. (See Part Identifier Key) Any parts damaged during shipment must be reported within 24 hours of receipt. To report information regarding damages or if you have any questions, please call 800.242.2303.

Tools Required

- Screw gun
- 1/2" wrench
- #S2 square bit

Step 1:

- Place the top face down on a protected flat surface.

Step 2:

- Place the LOBO frame on top of the top, with the tabs on the frame facing down. Align the tabs with pre-drilled pilot holes in the top.

Step 3:

- Starting at one corner, place the 5/16" leg bolt (that is welded to leg) through corner support brace of frame. Repeat for remaining legs.

Step 4:

- Using a # S2 square bit and screw gun, secure the leg plate to the top with #10 x 3/4" square pan screws. Repeat for each leg plate.

Step 5:

- Place 5/16" lock washer and 5/16" hex nut onto the leg bolt and tighten with 1/2" wrench. Repeat for remaining legs.
- If adjustable leg was purchased, adjust the leg to desired height.

Step 6:



- Using a # S2 square bit, secure frame to top with #10 x 3/4" square pan screws, using one screw per tab.

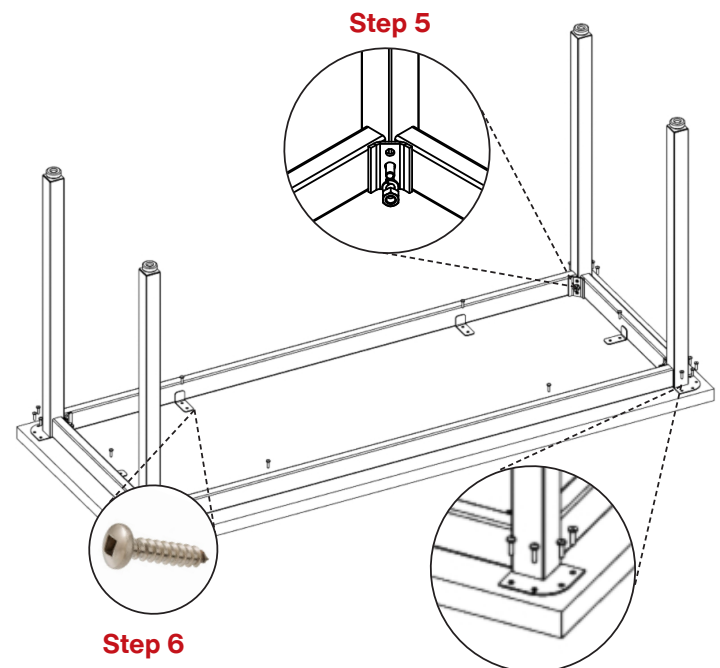
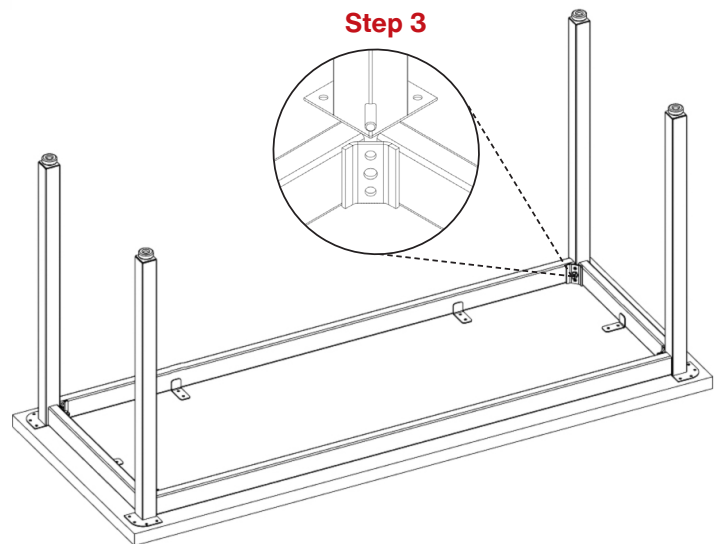

Step 7:



- Turn table to the upright position with the help of another person.



Part Identifier Key

Part #	Description	Qty.	
0408231	#10 x 3/4" square pan screws <i>(Used to attach leg plates and frame to top.)</i>	26 <i>(Included in hardware pack located in leg box. May need less depending on size of top.)</i>	
Hardware Pack 040379	5/16" lock washers	4	
	5/16" hex nuts <i>(Used to attach legs to frame.)</i>	4	

Part #	Description	Qty.	
04066968	3" Heavy Duty Caster Hardware Pack - Used only with 2" adj. legs (-ALR & -ABP) (Discard if casters are not installed.)		
	1/4" star washers (04067460)	4 per set	
	M6 1x18 screws (04067064)	4 per set	

Part #	Description	Qty.	
0402020	3" Heavy Duty Caster Hardware Pack - Used only with 1.5" adj. legs (-ADJ) (Discard if casters are not installed.)		
	1/4" star washers (04067460)	4 per set	
	M6 1x14 screws (0401259)	4 per set	

LOBO Legs

Adjustable Legs

Model #	Smooth Silver Sku #	Black Sku#	Description	Weight	Leg Height"
LOB -ADJ	0409195-G4	0409195	LOBO 1.5" (40mm) Square Adj. Leg	18	22.25 - 36.25
LOB -ALR	0409193-G4	0409193	LOBO 2" (50mm) Round Adj. Leg	20	22.25 - 36.25
LOB -ABP	N/A	0409196	LOBO 2" (50mm) Big Paw Sq. Adj. Leg	20	22.25 - 36.25



Fixed Legs

Model #	Smooth Silver Sku #	Black Sku#	Description	Weight	Leg Height"
LOB -FX	0409194-G4	0409194	LOBO 1.5" (40mm) Square Fixed Leg	16	28.75



Assembly Instructions

LOBO Table

w/Gussets

Step 1:

- Make sure that legs are fully installed and adjusted to the correct height.
- Place gusset in corner where leg and frame meet. Use a rubber mallet to tap the #10 self-drilling screws into place.

Step 2:

- Using a screw gun along with a 5/16" hex bit to finish fastening the gussets to the leg and frame with the #10 self-drilling screws.
- Repeat for remaining gussets.

Step 3:

- Turn table to the upright position with the help of another person.



Before you begin, please make sure all parts and proper quantities are included. (See Part Identifier Key) Any parts damaged during shipment must be reported within 24 hours of receipt. To report information regarding damages or if you have any questions, please call 800.242.2303.

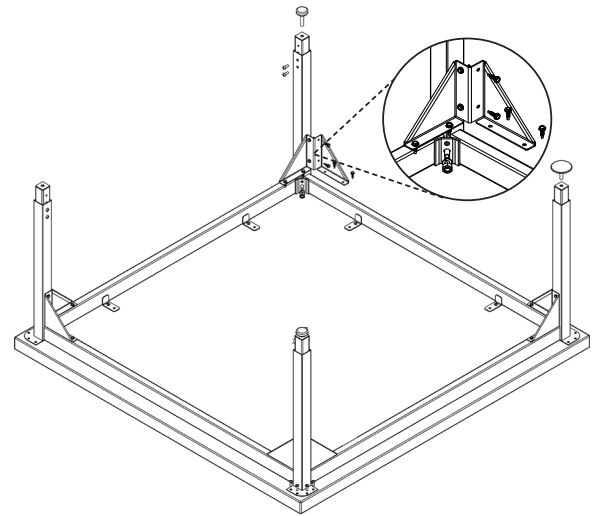

Tools Required

- 5/16" wrench
- Screw gun
- Rubber mallet



Part Identifier Key

Part #	Description	Qty.	
04066920	Gussets w/Hardware Pack - Used only with square LOBO legs		
	#10-16 x 3/4" hex head self-drilling screws (04009742)	8 per gusset	
	Gusset for square legs	1 per leg	

Part #	Description	Qty.	
04066918	Gussets w/Hardware Pack - Used only with round LOBO legs		
	#10-16 x 3/4" hex head self-drilling screws (04009742)	6 per gusset	
	Gusset for round legs	1 per leg	

Assembly Instructions

LOBO Tables

w/ Casters/Glides

Installing casters on tables with epoxy resin tops will void the epoxy warranty.

NOTE: Casters are not to be used as a leveling device. Loctite on casters will cause some resistance while tightening, please make sure that casters are tightened all the way to prevent possible damage to the stem of the caster.

Before you begin, please make sure all parts and proper quantities are included. (See Part Identifier Key) Any parts damaged during shipment must be reported within 24 hours of receipt. To report information regarding damages or if you have any questions, please call 800.242.2303.

Tools Required

- Screw gun
- 1/2" wrench
- #S2 square bit

Step 1:

- Remove nylon glide from leg by rotating counter-clockwise until glide is free.

Step 2:

- Place stem of optional footing into the hole on the leg. Rotate clockwise until fully inserted into leg.

Step 3:



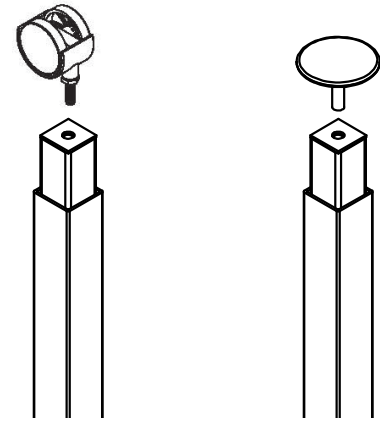

- Tighten with a 14mm open-ended wrench. (Only for the dual wheel soft tread locking caster.)

Step 4:

- Repeat for each caster or glide.



Part Identifier Key

Part #	Description	Qty.	
040164	2.5" Grand Hank glide, 3/8-16 x 1"	1 per leg	
04067920	1.5" soft touch glide	1 per leg	
NSL-33056S	1.25" steel glide	1 per leg	
04067540	Dual wheel soft tread locking casters (N/A on epoxy resin tops)	1 per leg	

LOBO Legs

Adjustable Legs

Model #	Smooth Silver Sku #	Black Sku#	Description	Weight	Leg Height"
LOB -ADJ	0409195-G4	0409195	LOBO 1.5" (40mm) Square Adj. Leg	18	22.25 - 36.25
LOB -ALR	0409193-G4	0409193	LOBO 2" (50mm) Round Adj. Leg	20	22.25 - 36.25
LOB -ABP	N/A	0409196	LOBO 2" (50mm) Big Paw Sq. Adj. Leg	20	22.25 - 36.25



Fixed Legs

Model #	Smooth Silver Sku #	Black Sku#	Description	Weight	Leg Height"
LOB -FX	0409194-G4	0409194	LOBO 1.5" (40mm) Square Fixed Leg	16	28.75



Assembly Instructions

LOBO Tables

w/ Heavy Duty Casters

Installing casters on tables with epoxy resin tops will void the epoxy warranty.

Castors are NOT to be used as a leveling device.

Step 1:

- Lock the caster by pushing down on the brake lever.

Step 2:

- Twist the stem of the caster into the hole on the bottom of the leg. Pre-applied thread locking adhesive will help prevent unexpected loosening and may cause slight resistance while tightening the caster.

Step 3:

- Use 1 1/8" wrench to tighten 3/4" nut on stem of caster.

Step 4:

- If using adj. legs, insert star washer and M6 screw in hole closest to the caster and tighten with 4mm hex wrench. DO NOT OVER TIGHTEN.
- If using a FIXED leg, you will NOT need to use a star washer and M6 screw.

Step 5:

- Repeat for remaining casters.

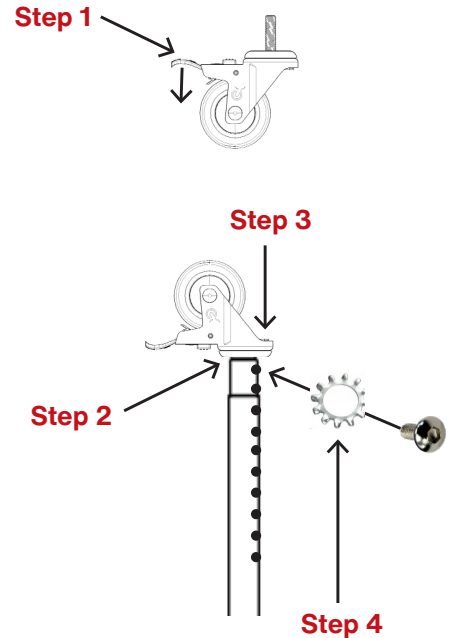

Before you begin, please make sure all parts and proper quantities are included. (See Part Identifier Key) Any parts damaged during shipment must be reported within 24 hours of receipt. To report information regarding damages or if you have any questions, please call 800.242.2303.

<p>Tools Required</p> <ul style="list-style-type: none"> • 1 1/8" wrench • 4mm hex wrench
--



Part Identifier Key

Part #	Description	Qty.	
0400993	3" heavy duty locking casters	1 per leg	

Part #	Description	Qty.	
04066968	3" Heavy Duty Caster Hardware Pack - Used only with 2" adj. legs (-ALR & -ABP)		
	1/4" star washers (04067460)	4 per set	
	M6 1x18 screws (04067064)	4 per set	

Part #	Description	Qty.	
0402020	3" Heavy Duty Caster Hardware Pack - Used only with 1.5" adj. legs (-ADJ)		
	1/4" star washers (04067460)	4 per set	
	M6 1x14 screws (0401259) <i>(Used in leg insert to prevent bending of the leg insert)</i>	4 per set	