

Assembly Instructions

LOBO Table

Stainless Steel Top

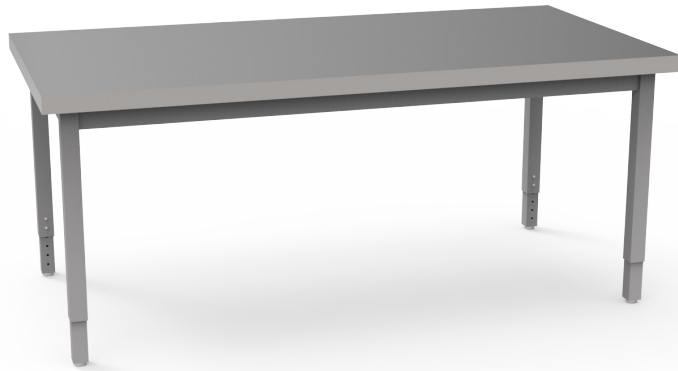

Before you begin, please make sure all parts and proper quantities are included. (See Part Identifier Key) Any parts damaged during shipment must be reported within 24 hours of receipt. To report information regarding damages or if you have any questions, please call 800.242.2303.

Tools Required

- 1/2" wrench
- Screw gun
- #S2 square bit

Step 1:

- Place the top face down on a protected flat surface.

Step 2:

- Place LOBO frame tabs down on top of the top and align the frame tabs with pre-drilled pilot holes in the top.

Step 3:

- Using a # S2 square bit, secure frame to top with #10 x 3/4" square pan screws using one screw per tab.

Step 4:

- Starting at one corner, place the 5/16" bolt that is welded to leg through corner support brace of frame.

Step 5:

- Place the 5/16" lock washer and 5/16" hex nut onto the leg bolt and tighten with 1/2" wrench. Repeat **Steps 4 & 5** on remaining legs.

Step 6:

- Use a 5/16" hex bit to secure the leg plate to the top with #10 16x3/4" hex washer head self-drilling screws. Table will not have pre-drilled holes for the leg plates.

Step 7:

- Adjust the leg to desired height.

Step 8:

- With someone's help, turn table upright.

Step 9:

- There will be a laser film applied to the top to prevent scratches during transport. Remove film from the top. We recommend using a solvent containing MEK to help with ease of removal of the film.

Steps 4 & 5

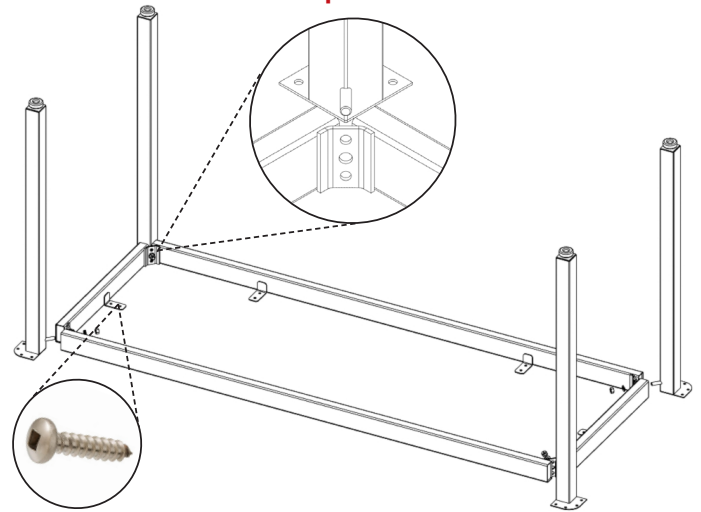



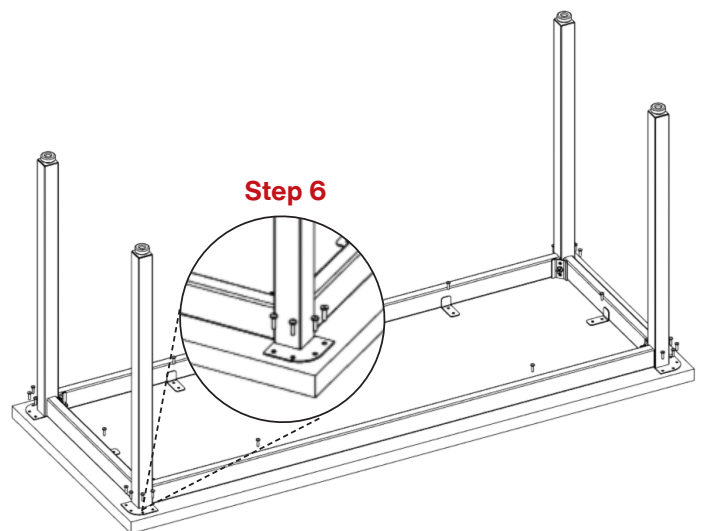



Step 3





Step 6

Part Identifier Key

Part #	Description	Qty.	
0408231	#10 x 3/4" square pan screws <i>(Used to attach frame to top.)</i>	26 <i>(Included in hardware pack located in leg box. May have extra depending on size of top.)</i>	
04009742	#10 16x3/4" hex washer head self-drilling screws <i>(Used to attach leg plates to top.)</i>	16 <i>(Hardware pack not included in leg box.)</i>	
Hardware Pack	5/16" lock washers	4	
040379	5/16" hex nuts <i>(Used to attach legs to frame.)</i>	4	

Part #	Description	Qty.	
04066968	3" Heavy Duty Caster Hardware Pack - Used only with 2" adj. legs (-ALR & -ABP) (Discard if casters are not installed.)		
	1/4" star washers (04067460)	4 per set	
	M6 1x18 screws (04067064)	4 per set	

Part #	Description	Qty.	
0402020	3" Heavy Duty Caster Hardware Pack - Used only with 1.5" adj. legs (-ADJ) (Discard if casters are not installed.)		
	1/4" star washers (04067460)	4 per set	
	M6 1x14 screws (04067064)	4 per set	

LOBO Legs

Adjustable Legs

Model #	Smooth Silver Sku #	Black Sku#	Description	Weight	Leg Height"
LOB -ADJ	0409195-G4	0409195	LOBO 1.5" (40mm) Square Adj. Leg	18	22.25 - 36.25
LOB -ALR	0409193-G4	0409193	LOBO 2" (50mm) Round Adj. Leg	20	22.25 - 36.25
LOB -ABP	N/A	0409196	LOBO 2" (50mm) Big Paw Sq. Adj. Leg	20	22.25 - 36.25



Fixed Legs

Model #	Smooth Silver Sku #	Black Sku#	Description	Weight	Leg Height"
LOB -FX	0409194-G4	0409194	LOBO 1.5" (40mm) Square Fixed Leg	16	28.75



Gussets are only available on rectangle and round shaped tables.

Step 1:

- Make sure that legs are fully installed and adjusted to the correct height.

Step 2:

- Place gusset in corner where leg and frame meet. Use a rubber mallet to tap #10-16 x 3/4" hex head self-drilling screws into place.

Step 3:

- Using a screw gun along with a 5/16" hex bit. fasten the gussets to the leg and frame with #10-16 x 3/4" hex head self-drilling screws.

Step 4:

- Repeat for remaining gussets.



Before you begin, please make sure all parts and proper quantities are included. (See Part Identifier Key) Any parts damaged during shipment must be reported within 24 hours of receipt. To report information regarding damages or if you have any questions, please call 800.242.2303.

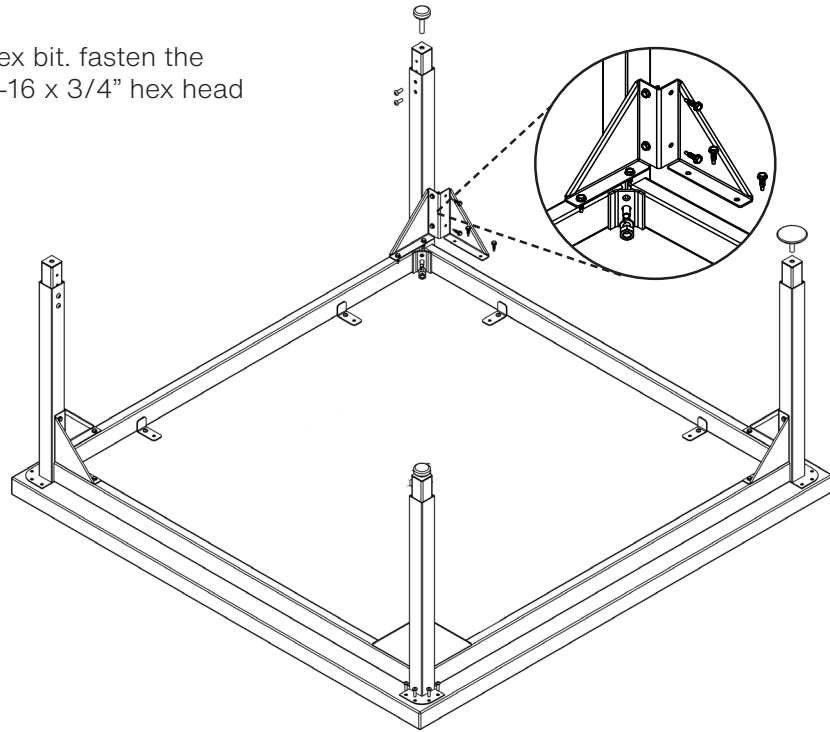

Tools Required

- Screw gun
- 1/2" wrench
- #S2 square bit



Part Identifier Key

Part #	Description	Qty.	
04066920	Gussets w/ hardware pack - Used only with square LOBO legs		
	#10-16 x 3/4" hex head self-drilling screws (04009742)	8 per gusset	
	Gusset for square legs	1 per leg	

Part #	Description	Qty.	
04066918	Gussets w/ hardware pack - Used only with round LOBO legs		
	#10 Self-drilling screws (04009742)	6 per gusset	
	Gusset for round legs	1 per leg	

Installing casters on tables with epoxy resin tops will void the epoxy warranty.

NOTE: Casters are not to be used as a leveling device. Loctite on casters will cause some resistance while tightening, please make sure that casters are tightened all the way to prevent possible damage to the stem of the caster.

Before you begin, please make sure all parts and proper quantities are included. (See Part Identifier Key) Any parts damaged during shipment must be reported within 24 hours of receipt. To report information regarding damages or if you have any questions, please call 800.242.2303.

Tools Required

- Screw gun
- 1/2" wrench
- #S2 square bit

Step 1:

- Remove nylon glide from leg by rotating counter-clockwise until glide is free.

Step 2:

- Place stem of optional footing into the hole on the leg. Rotate clockwise until fully inserted into leg.

Step 3:



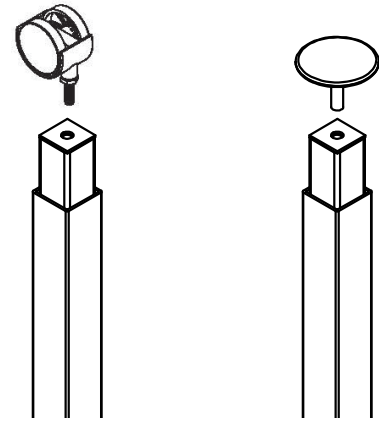

- Tighten with a 14mm open-ended wrench. (Only for the dual wheel soft tread locking caster.)

Step 4:

- Repeat for each caster or glide.



Part Identifier Key

Part #	Description	Qty.	
040164	2.5" Grand Hank glide, 3/8-16 x 1"	1 per leg	
04067920	1.5" soft touch glide	1 per leg	
NSL-33056S	1.25" steel glide	1 per leg	
04067540	Dual wheel soft tread locking casters (N/A on epoxy resin tops)	1 per leg	

LOBO Legs

Adjustable Legs

Model #	Smooth Silver Sku #	Black Sku#	Description	Weight	Leg Height"
LOB -ADJ	0409195-G4	0409195	LOBO 1.5" (40mm) Square Adj. Leg	18	22.25 - 36.25
LOB -ALR	0409193-G4	0409193	LOBO 2" (50mm) Round Adj. Leg	20	22.25 - 36.25
LOB -ABP	N/A	0409196	LOBO 2" (50mm) Big Paw Sq. Adj. Leg	20	22.25 - 36.25



Fixed Legs

Model #	Smooth Silver Sku #	Black Sku#	Description	Weight	Leg Height"
LOB -FX	0409194-G4	0409194	LOBO 1.5" (40mm) Square Fixed Leg	16	28.75



Assembly Instructions

LOBO Table w/Heavy Duty Casters

Before you begin, please make sure all parts and proper quantities are included. (See Part Identifier Key) Any parts damaged during shipment must be reported within 24 hours of receipt. To report information regarding damages or if you have any questions, please call 800.242.2303.

Installing casters on tables with epoxy resin tops will void the epoxy warranty.

Castors are NOT to be used as a leveling device.

Step 1:

- Lock the caster by pushing down on the brake lever.

Step 2:

- Twist the stem of the caster into the hole on the bottom of the leg. Pre-applied thread locking adhesive will help prevent unexpected loosening and may cause slight resistance while tightening the caster.

Step 3:

- Use 1 1/8" wrench to tighten 3/4" nut on stem of caster.

Step 4:

- If using adj. legs, insert star washer and M6 screw in hole closest to the caster and tighten with 4mm hex wrench. DO NOT OVER TIGHTEN.
- If using a FIXED leg, you will NOT need to use a star washer and M6 screw.

Step 5:

- Repeat for remaining casters.

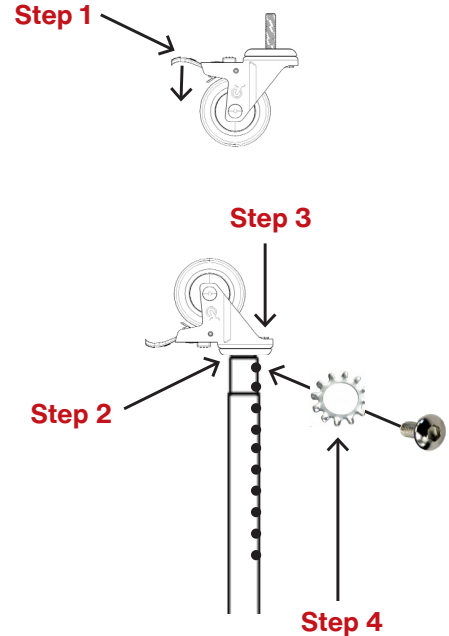

Tools Required

- 1 1/8" wrench
- 4mm hex wrench



Part Identifier Key

Part #	Description	Qty.	
0400993	3" heavy duty locking casters	1 per leg	

Part #	Description	Qty.	
04066968	3" Heavy Duty Caster Hardware Pack - Used only with 2" adj. legs (-ALR & -ABP)		
	1/4" star washers (04067460)	4 per set	
	M6 1x18 screws (04067064)	4 per set	

Part #	Description	Qty.	
0402020	3" Heavy Duty Caster Hardware Pack - Used only with 1.5" adj. legs (-ADJ)		
	1/4" star washers (04067460)	4 per set	
	M6 1x14 screws (0401259) <i>(Used in leg insert to prevent bending of the leg insert)</i>	4 per set	