



We Can.
DESIGN. BUILD. DELIVER.

WB Mfg
WB Manufacturing LLC

**casework** USA[®]
BY WB MANUFACTURING

Installation Guide

800.242.2303 | info@wibenchmfg.com | www.wibenchmfg.com

Overview	Page
Shipment Problems	2
Backcharges Policy	2
Who Furnishes What	2
Building Conditions	2
Quick Tips	3
Product Receiving Procedures	3
Fasteners	4
Toe Base Platform	5
Base & Tall Cabinets	6
Wall Cabinets	7
Scribes/Fillers	8
Countertops	9
Kneespace Drawer	9
Apron	9
Finished Back Panels	10
Ceiling Scribes	10
Soffits	10
Sloped Top	10
Pedestal Supports	11
Reception Desks	11
Final Adjustments	12
Finishing Touches	12

Introduction

This Installation Guide contains our recommended procedures for installing WB Manufacturing's CaseworkUSA® Cabinets. There is also information about product receiving & identifying, fasteners, and adjustments. Please read the **entire** Installation Guide before beginning.

Shipment Problems

Problems related to damaged product, incorrect cabinet sizes or hardware should be brought to the attention of the authorized WB Manufacturing Dealer representative on the job before contacting WB Manufacturing. Use the Missing or Damaged Parts form enclosed with the project shipping list.

Backcharges Policy

All situations to which backcharges may apply are to be brought to the attention of the authorized WB Manufacturing Dealer and WB Manufacturing before corrective measures are taken. WB Manufacturing must approve and give written authorization for the corrective action before the work begins.

Who Furnishes What

Factory Furnished

- Casework: Cabinets, scribes, fillers, and finished backs
- Toe Base Platform Material: 4" x 96" x 3/4" plywood (if using a ladder base, otherwise it will be attached).
- Shop Drawings & Shipping Lists
- Pulls (attached backwards)
- Shelves and shelf clips (loose)
- Other parts as indicated "By WB Manufacturing" on Shop Drawings.

Installer Furnished

- Installation tools and equipment
- Fastening devices
- Stripping, blocking, furring, and/or sleepers required from face of walls, floors, or ceilings.
- Color fill

General Contractor Furnished

- Structural Members: Grounds, backing or blocking in walls, ceilings or floors
- Electrical power and water service
- Hoisting services
- Caulking to fill any wall imperfection
- Clean, dry, ventilated, secure, indoor location free from excessive humidity and extreme temperatures for cabinet delivery and storage.

Building Conditions

WB Manufacturing will **NOT** be responsible for damage to casework or related materials due to inappropriate storage or installation conditions at the building site. Delivery of casework shall be made **only** when the area of operation is enclosed, all plaster and concrete work dry, and the area broom clean. A clean storage area, well-ventilated and protected from direct sunlight, excessive heat and moisture, in which the relative humidity is between 45% and 65% at 60°F to 85°F with moisture content between 8% and 12%, shall be provided and maintained at the building site by the General Contractor. The air conditioning or heating system shall be on and functioning, and the casework shall be acclimated to these conditions for 72 hours prior to installation.

WB Customer Service

Email: info@wibench.com

Phone: 800.242.2303

Quick Tips

- To save time distributing cabinets, mark room numbers on the floor at the room opening for fast identification.
- For removing damaged edgebanding, use a household iron to reactivate the adhesive, and pull off the edgebanding.
- Secure bottom and top returns of wall cabinet scribes with construction adhesive, no screws are needed.
- To assure proper alignment of cabinet face and ends, use rubber-tipped or wood clamps to hold the end panels in place while securing the backs and sides.
- A water or laser level are excellent for leveling long runs of casework on uneven floors.
- Lubricate moving parts with general household lubricant.

Product Receiving

- Job orientation for all installers, before and during, delivery of the first shipment is recommended. Installers should be familiar with WB Manufacturing cabinet construction, Labels, Shipping Lists, Shop Drawings and the building's layout.
- Scheduled truck arrival will be confirmed by driver 24 hours before delivery.
 - Freight charges include six (6) hours for unloading at the site. Additional charges, at \$50 per hour, apply for any time over six (6) hours.
 - Remove banding carefully to prevent damage to cabinets. Leave corner protection and film wrap on until cabinets are ready to be installed.
 - Verify receipt of all items in the shipment as they are removed from the trailer. An WB Manufacturing Cabinet Sticker is attached to each item. The number on each Cabinet Ticket corresponds with the items on the Shipping List.
 - Before signing the Shipping List, account for all items, note all damages or shortages (include Elevation #, Room #, Item# and Color), and note any unusual circumstances, such as late truck arrival, adverse unloading conditions, etc.
 - Fasteners for casework are not provided. See Page 4 for recommendations.

ORDER NO:
(On Cover Sheet)

JOB NAME:
(On Cover Sheet)

COMPANY: (On Cover Sheet)

PHASE #:

ROOM #:

SHOP DRAWING ELEVATION:

SHOP DRAWING CABINET #:

CABINET MODEL #:

SHIP DATE:

PACKING DATE:





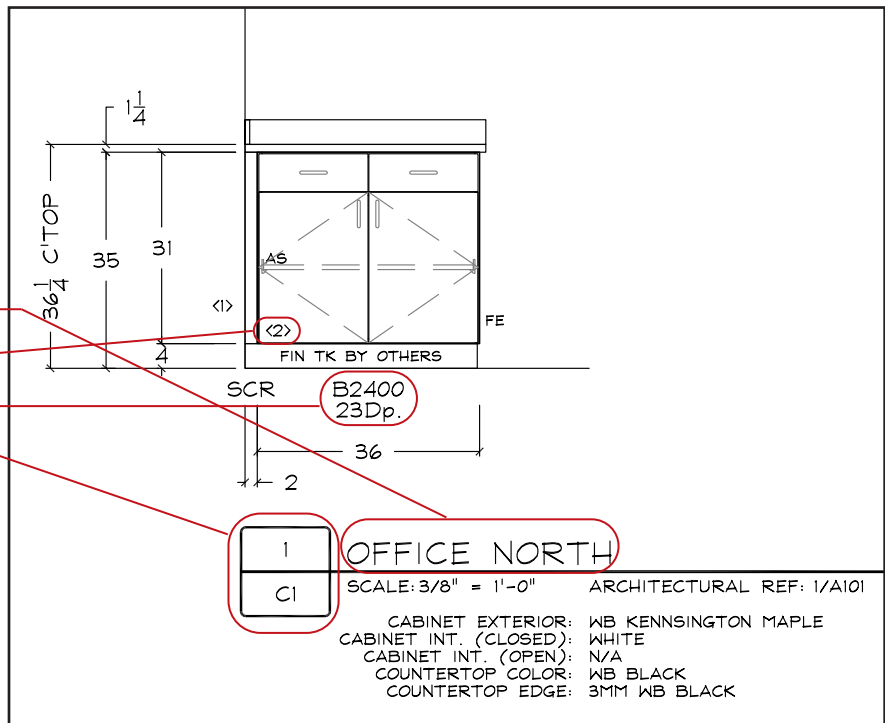

ICN9655200

casework USA Production Date
This product contains plywood, MDF and particleboard that complies with
CARB Phase 1 formaldehyde emission standards in CCR 93120 2(a)

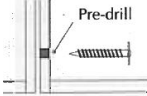
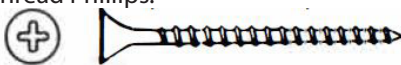
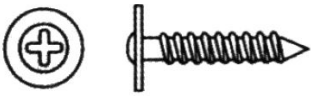
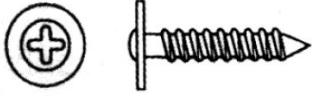

Fasteners

WB Manufacturing recommends the following fasteners for securing casework. All fasteners exposed to view (not behind solid doors or drawers) must be chrome or zinc. Pilot holes should be drilled for all fasteners.

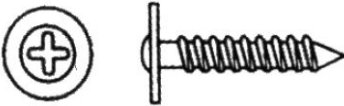
Description	Application	Pilot Hole
<p>#14 x 3" heavy-duty, zinc fastener with drill point and truss head. Use #3 tip.</p> 	<p>Cabinet Back to:</p> <ul style="list-style-type: none"> • Wood Blocking (sharp pt.) • 25 ga.-16 ga. steel stud • Concrete block • Steel blocking 	<p>Pre-drill 1/4" hole in cabinet back. At concrete block, pre-drill with 3/16" masonry bit.</p>
		<p>Pre-drill, pre-toggler Bolt Manufacturing Specifications</p>
<p>1 1/4" Truss/washer. At sliding door condition, use flathead only.</p> 	<p>Cabinet end panel to cabinet end panel.</p>	<p>Pre-drill one cabinet end panel with 3/16" hole. Pilot hole should be slightly bigger than the screw. This allows the screw to pull the two cabinets together.</p> 
<p>Drywall Screw or #7 x 1 5/8" flathead deep thread Phillips.</p> 	<p>Toe base platform to cabinet to base skid.</p>	<p>Pre-drill 1/8" with countersink.</p>
<p>#8 x 1 1/4" Truss/washer</p> 	<p>Laminate countertop</p>	<p>Pre-drill 3/16" in cabinet subtop.</p>
<p>Polyurethane sealant/adhesive (provided by installer)</p>	<p>Phenolic/Epoxy resin countertops</p>	<p>Do not drill into Phenolic/Epoxy resin countertops, need to use polyurethane sealant/adhesive (provided by installer).</p>
<p>#8 Truss/washer or flathead deep thread at sliding doors (only), zinc.</p> 	<p>Scribes</p>	<p>Pre-drill cabinet end panel with 3/16" hole.</p>
<p>#8 x 1 3/4" Truss head</p> 	<p>Finished backs</p>	<p>Pre-drill cabinet with 3/16" hole.</p>
<p>#8 x 1 1/2" Truss/washer</p> 	<p>Removable panels</p>	<p>Pre-drill removable panel with 3/16" hole.</p>

Assembly

The Toe Base Platform is field-assembled from 3/4" x 4" x 96" pre-cut lengths of exterior-grade plywood. Cut pieces to appropriate lengths and assemble them in a "ladder" design consisting of back, front, ends, and intermediates. Back will be positioned against the wall. Front will be inset 3" from face of cabinet door. Check actual cabinet depth, allowing for mechanical chase behind cabinet if applicable. Bottom of cabinet has a toe base attachment skid. The front of this skid should fall just behind the front of the platform. Ends will be inset 1/4" from face of cabinet Finished End.

Position

intermediates under cabinet end panels.

Installation

Snap a level line in both directions from high point of floor. Place the platform in position. Work from the high spot on the floor in both directions, leveling (side-to-side and front-to-back) and shimming. Fasten platform back to the wall every 16" into wall studs or blocking. For island and peninsula applications, attach blocking to the floor every 24" maximum and face fastening the platform to the blocking. Shim as required.

Toe Base Platform

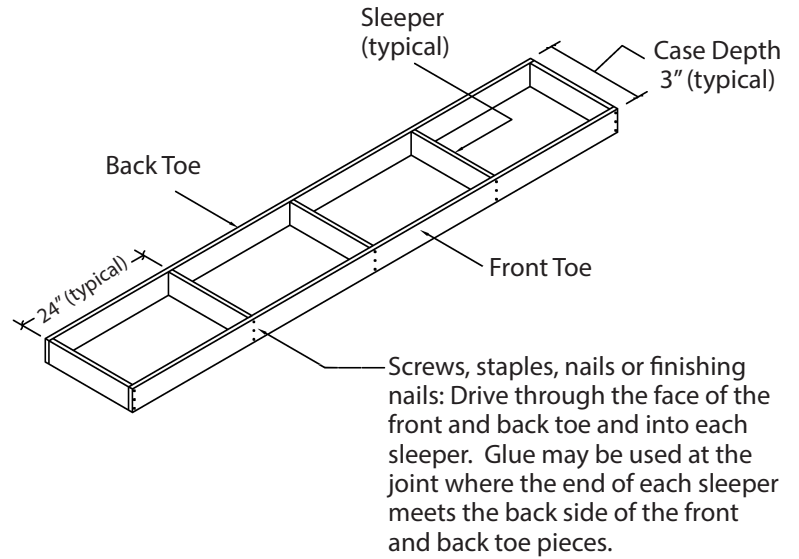

Cabinet Position on Platform

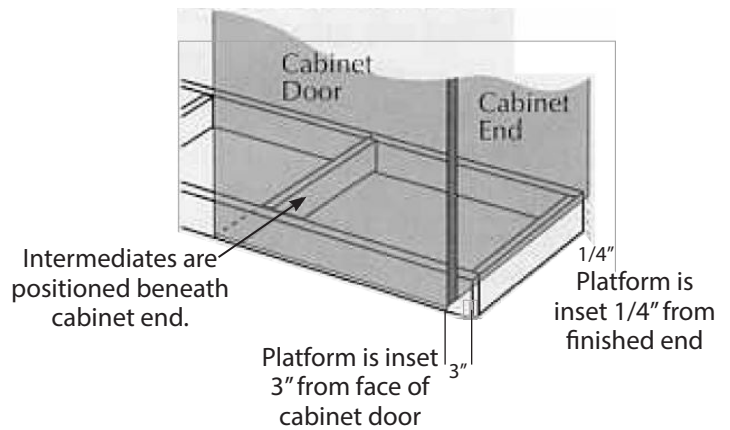

Finished End Inset (Back View)

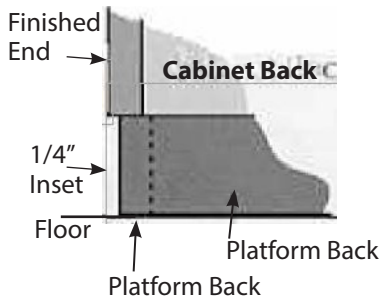

Cabinet Front Inset (Side View)

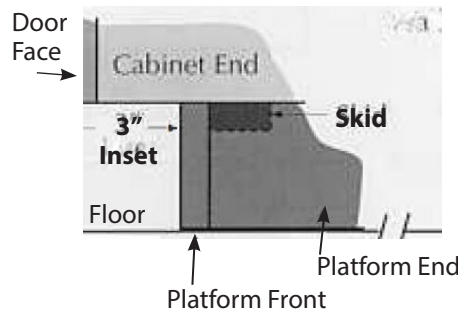

Island & Peninsula Blocking (Side View)

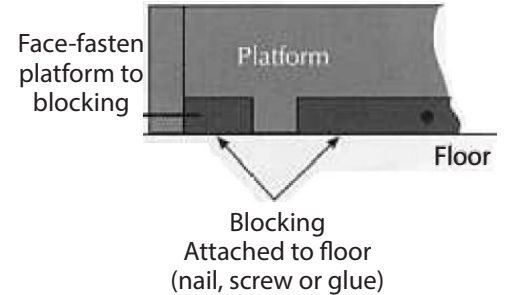

Shimming at Wall (Top View)

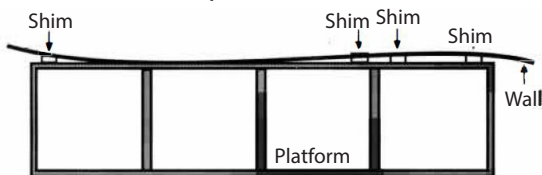

Shimming at Floor (Side View)

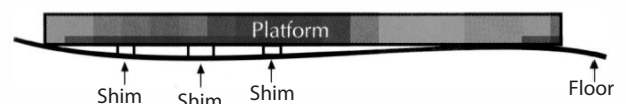

- Set cabinets on toe base platform.
- Fasten cabinet end panels together at equal intervals. Shim behind cabinets to accommodate uneven walls and keep joined end panels from separating.
- After all cabinets are joined to each other, attach cabinets to wall. Fasten through cabinet back panels into wall studs or blocking.
- Attach cabinets to toe base platform by fastening through the platform front into the toe base attachment strip on bottom of cabinet.

Position Cabinets on Platform Fasten End Panels Together

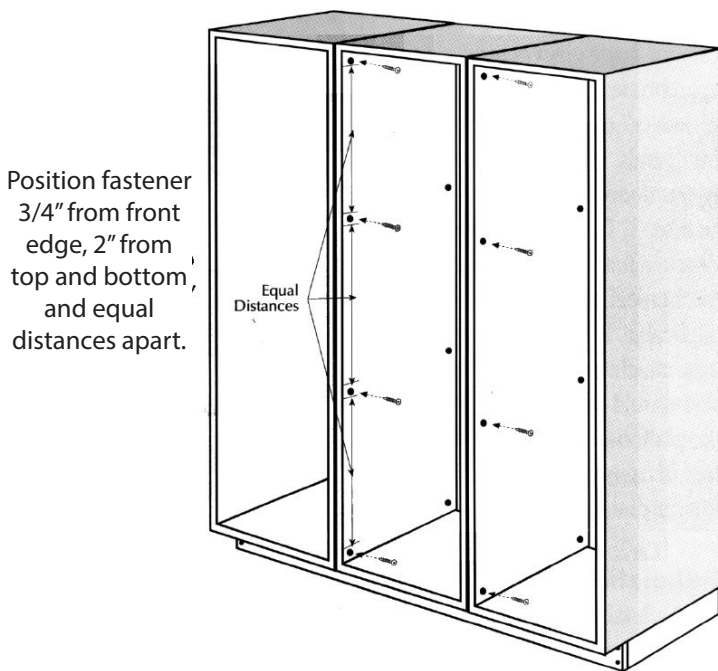

Shim Behind Cabinets (End View)

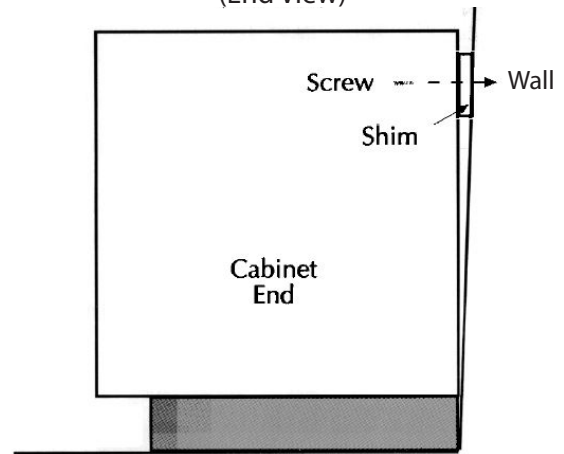

Attach Cabinet Run to Toe Base Platform (Side View)

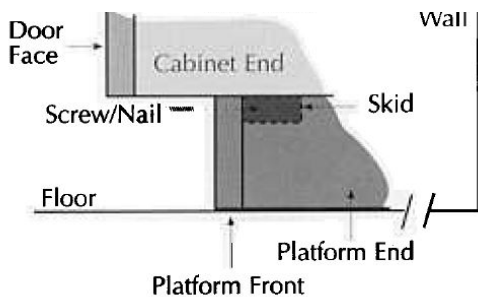

Shim Behind Cabinets (Top View)

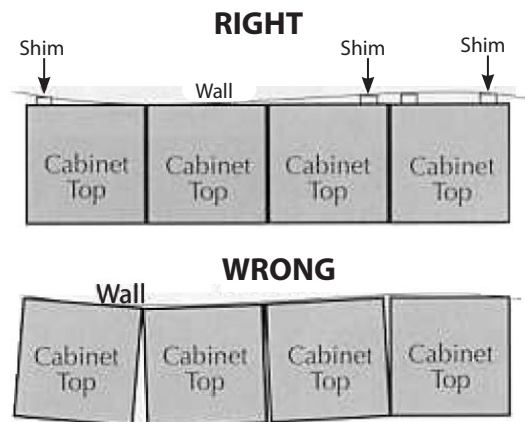

Wall Cabinets

- “String” wall to check for cups or bows. Determine if wall is perpendicular to floor. If wall is not completely flat and perpendicular to the floor, shimming will be required.
- Snap a chalk line on wall where tops of cabinets will align. Tops of wall and tall cabinets must align.
- Loose-fasten cabinets to wall, shimming as necessary. Attach cabinet to wall, using four fasteners per cabinet through cabinet back panel into studs or blocking.
- When cabinets are in place, fasten end panels together.
- When cabinet fronts are aligned, end panels are tight and back panels are shimmed properly, tighten all fasteners in all locations.

Align Tops of Wall & Tall Cabinets

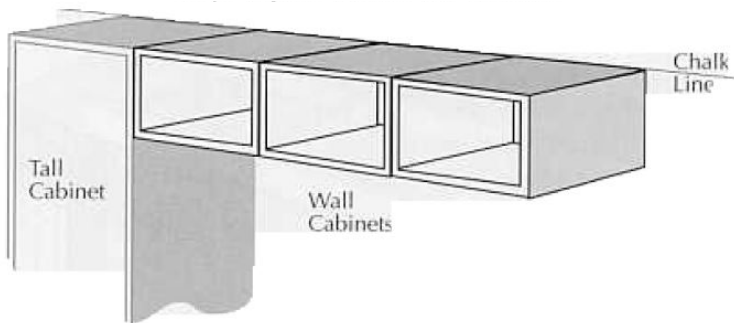

Fasten End Panels Together

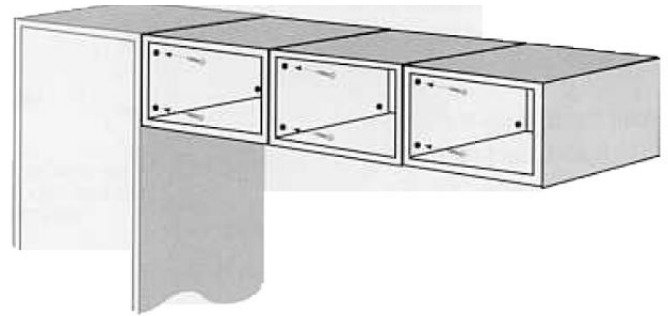

Shim Behind Cabinets (Top View)

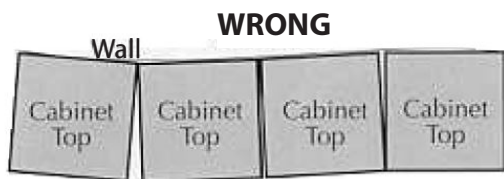
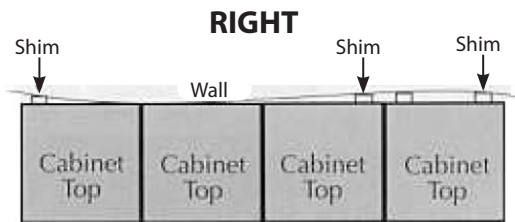

Attach Cabinet to Wall (Top View)

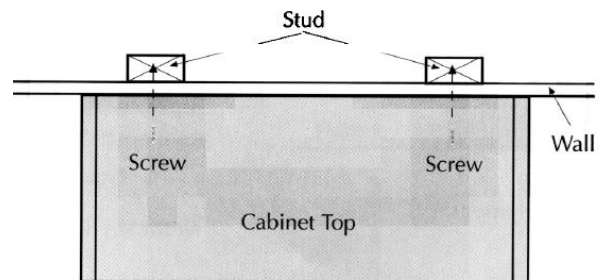

Special Attachment

(Where cabinet is too narrow to hit both studs or end of run as required.)

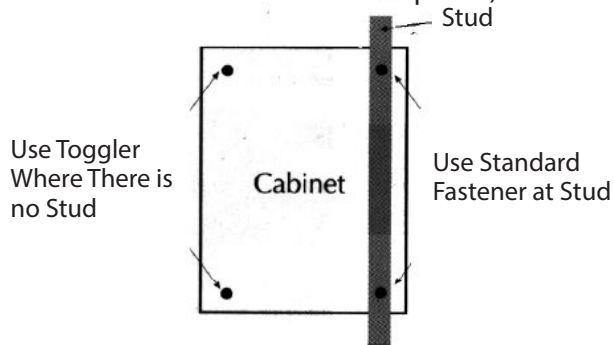

Scribes/Fillers

- Attach scribes/fillers through cabinet end panels.

Inside Corner Fillers

- Inside corner fillers consists of verticals (base, wall and tall cabinets), tops (wall and tall cabinets), and bottoms (wall cabinets).
- Cut vertical fillers according to Shop Drawings and fasten through both cabinet end panels.
- To support top and bottom fillers, secure blocking against walls and both cabinet end panels.
- Notch front corner of top and bottom fillers to fit flush against vertical filler.
- Attach top and bottom fillers with construction adhesive.
- Scribe visible wall cabinet bottom filler to fit flush with walls.

Attach Scribes/Fillers Through Cabinet End Panels

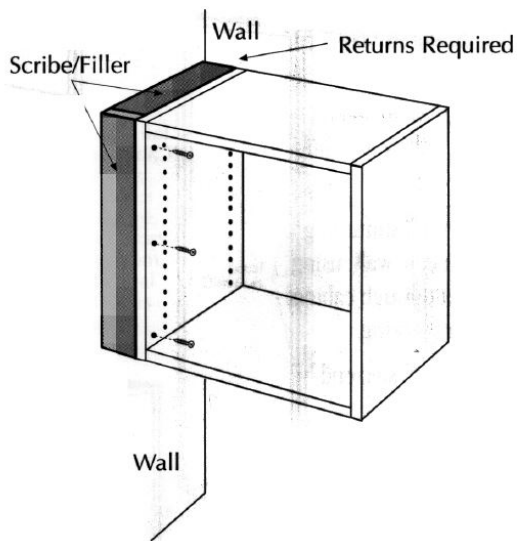

Inside Corner Fillers

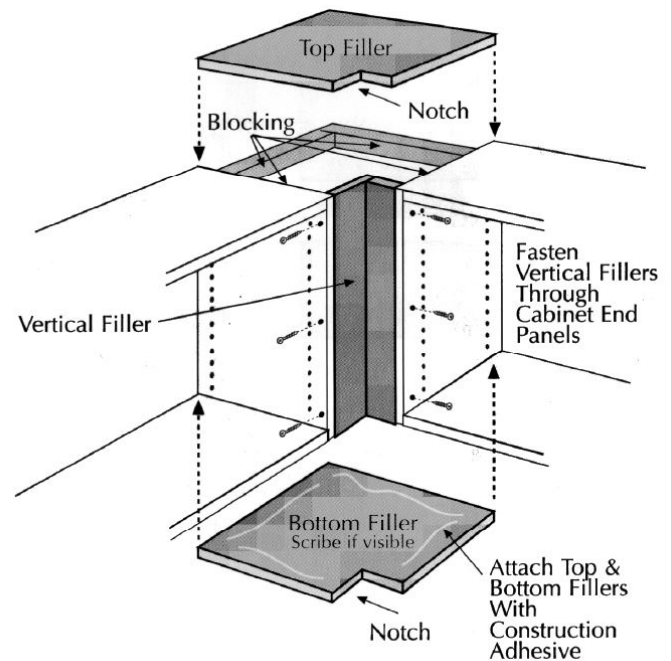

Countertops

Laminate Countertops

Attach countertop to cabinet subtop by fastening from inside the cabinet up through the subtop into the countertop. Fasten along the back and front of the countertop. If a cabinet has two or more top drawers, fasten on both sides of the vertical drawer divider. Set loose backsplash or endsplash in a continuous bead of clear silicone caulking. For countertops without cabinets, install continuous 3/4" x 3" ledger strip on wall, anchored to studs or blocking every 16". Attach countertop to ledger strip. Off-wall countertop support brackets must be installed to steel stud or in-wall horizontal blocking top and bottom of bracket.

Epoxy/Phenolic Resin Countertops

Follow the epoxy/phenolic resin manufacturer's installation guide. In addition, spread polyurethane sealant/adhesive (provided by installer) on cabinet subtop only at end panel edges. Never use any type of screws to attach epoxy/phenolic resin countertop to cabinet.

Laminate Countertop- Attach Countertop to Cabinet Subtop (Side View)

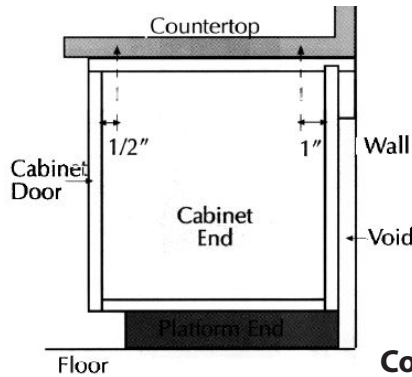

Laminate Countertop- Fasten on Both Sides of Drawer Divider. (Front View)

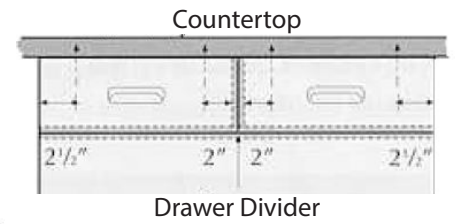

Counter Bracket

Brackets should be firmly mounted to solid walls and/or studs/blocking. Position to provide adequate support along entire length of countertop.

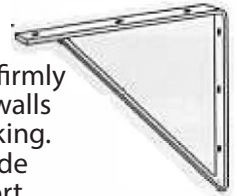

Epoxy/Phenolic Resin Countertops Glue at End Panels (Top View)

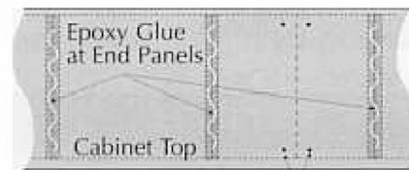

Kneespace Drawer

Remove drawers from kneespace frame. Mark drawers to ensure they are returned to the correct compartment. Attach kneespace frame to countertop at front and rear. If there are two or more drawers, fasten together at the center divider.

Attach Kneespace Frame to Countertop (Front View)

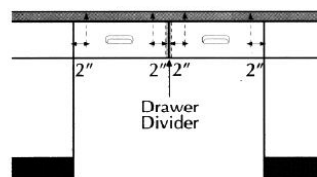

Attach Kneespace Frame Front & Back (Top View)

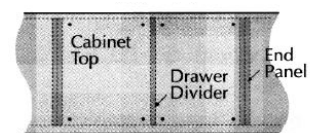

Apron

After trimming to field conditions, position face of laminate apron flush with adjacent cabinet front edges. Attach apron to countertop with 1" x 1" nylon angle brackets, at 18" intervals, starting 3" in from each end. Fasten apron ends with screws through the adjacent cabinet end panel.

Attach Apron to Countertop (Front View)

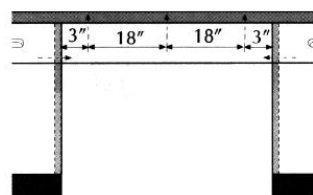

Fasten Apron to End Panels (Top View)

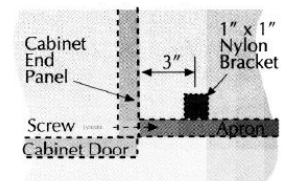

Finished Back Panels

Position Finished Back top and bottom edge flush with cabinet body. Position side edges for equal reveals with cabinet body or additional Finished Backs. Fasten through inside of cabinet at top and bottom, at 18" intervals.

Fasten Finished Back Panel to Cabinet Back
(Back View)

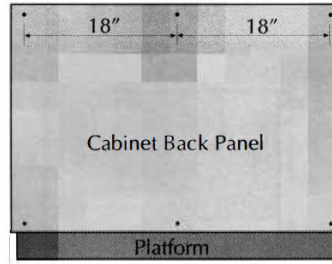

Position Finished Back Panel Flush with Top & Bottom of Cabinet (Side View)

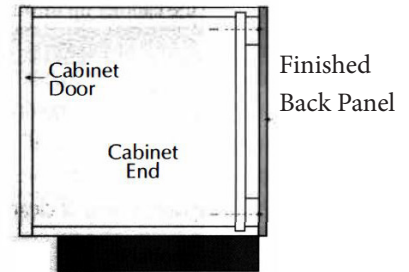

Ceiling Scribes

Scribes are typically planned 3/4" high to 2" high, and are positioned flush with the cabinet body front edge, unless detailed otherwise by Shop Drawings. Scribes 1" high or less are typically glued in position. Scribes over 1" high are screwed to the cabinet top.

Ceiling Scribe
(Front View)

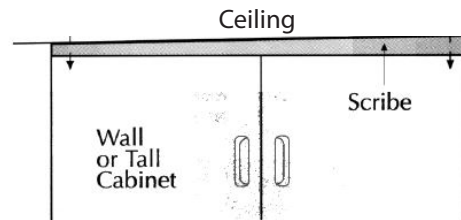

Soffits

Soffits contain a factory installed bottom return, for positioning the soffit face flush with the cabinet face. Trim and scribe soffit according to field conditions. Fasten the return portion of the soffit to the cabinet top, either from above or from inside the cabinet. Soffits over 12" tall will require additional diagonal bracing/blocking.

Soffit
(Side View)

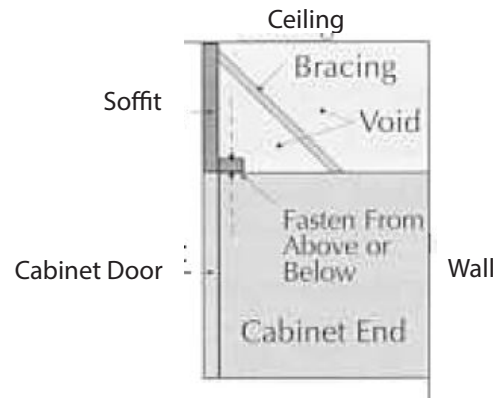

Sloped Top

Soffits contain a factory installed bottom return, for positioning the soffit face flush with the cabinet face. Trim and scribe soffit according to field conditions. Fasten the return portion of the soffit to the cabinet top, either from above or from inside the cabinet. Soffits over 12" tall will require additional diagonal bracing/blocking.

Sloped Top

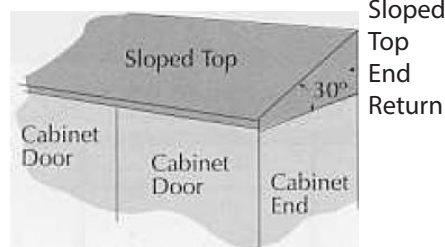

Sloped Top
(Side View)

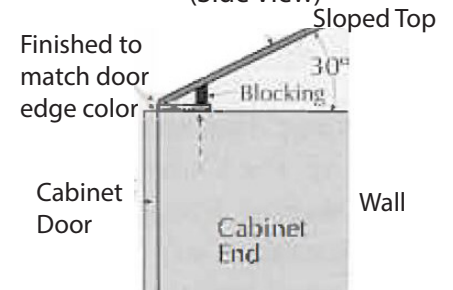

Pedestal Supports

Install two screws on the bottom edge of pedestal support, leaving 3/4" exposed to act as locator pins. Drill holes in the floor to correspond with the screws. Fill holes with construction adhesive and position pedestal locator screws in the holes. Attach pedestal to wall with 2" x 2" metal angles on unexposed side.

Pedestal Support

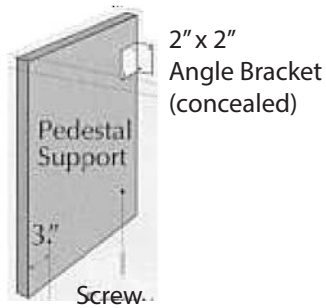

Attach Pedestal Support to Floor (Side View)

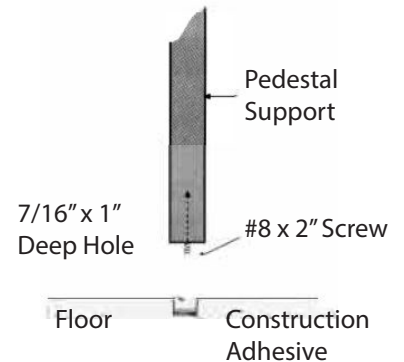

Reception Desks

Reception Desks are factory assembled in complete, finished length, under level conditions, then broken down into smaller components. Assemble the components according to the Shop Drawings. Attach blocking to the floor and fasten the level toe base platform to the blocking. Install the components.

Reception Desk

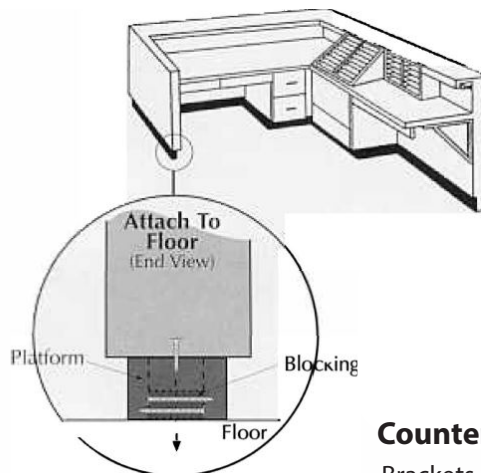

Level (End View)

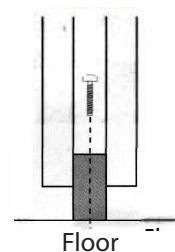

Countertop Bracket

Brackets should be firmly mounted to solid walls and/or studs/blocking. Position to provide adequate support along entire length of countertop. (See page 9)

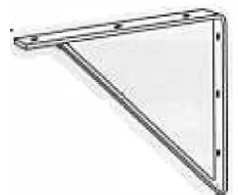

Final Adjustments

Lock Adjustments

The keys to cabinet locks are taped to the inside of the cabinet door or drawer. Should the lock's rear swing plate cam become loose, retighten with a Phillips screwdriver.

Drawer Slide Adjustment

For standard drawer slides, rotate offset cam (front of right hand cabinet body member) with flat-bladed screwdriver as necessary to increase or decrease drawer body travel tightness.

Hospital-Tipped Hinge Adjustment

Hospital-tipped hinges can be adjusted by bending the hinge part that is attached to the cabinet end panel.

Concealed Hinge Adjustment

Concealed hinges can be adjusted as follows. Use a Phillips head screwdriver.

- **Side Adjustment**
Turn front screw clockwise to increase door overlay, counter clockwise to decrease. Range = $5/32$ " (4mm)
- **Depth Adjustment**
Loosen back screw. Adjust door to position and tighten screw. Range = $5/32$ " (4mm)
- **Height Adjustment**
Loosen screw(s) on the mounting plate. Adjust door to position and tighten screws. Range= $1/4$ " (6mm)
- **Door Removal & Installation**
Release the lever under the hinge arm to remove. To reinstall, place the hinge on the mounting plate and push the back with finger pressure. The "clip" sound confirms a secure attachment.

Note: Apply a small amount of Loc-tite to screws after final adjustment to prevent loosening through use.

Finishing Touches

Touch-up and cleaning will be required after installation. Use household countertop spray cleansers, liquid soap, or window cleaner and a damp, white cloth or paper towels to clean cabinet exteriors, interiors and hardware. Never use harsh abrasives, caustic cleansers, scouring pads or steel wool as they will scratch the finishes. Clean epoxy tops per manufacturers instructions.

WB Manufacturing • 507 E. Grant St. • Thorp, WI 54771

We Can.
DESIGN. BUILD. DELIVER.

