

Installation Instructions

REplay® Interlock Wall System Kit

Before you begin, please make sure all parts and proper quantities are included. (See Part Identifier Key) Any parts damaged during shipment must be reported within 24 hours of receipt. To report information regarding damages or if you have any questions, please call 800.242.2303.

Tools Required

- Screw gun
- Level
- Metal file

Step 1:

- Snap mounting bracket to correct length for wall construction and file off any burrs or sharp corners that may be exposed if cabinet is moved.
- Mount the bracket to the wall so the distance from the floor to the center of the screws is 25.5". (Installers should verify field dimensions as site circumstances may vary.)
- Fasteners for mounting the bracket to the wall are to be supplied by the customer and should be appropriate for the wall construction.

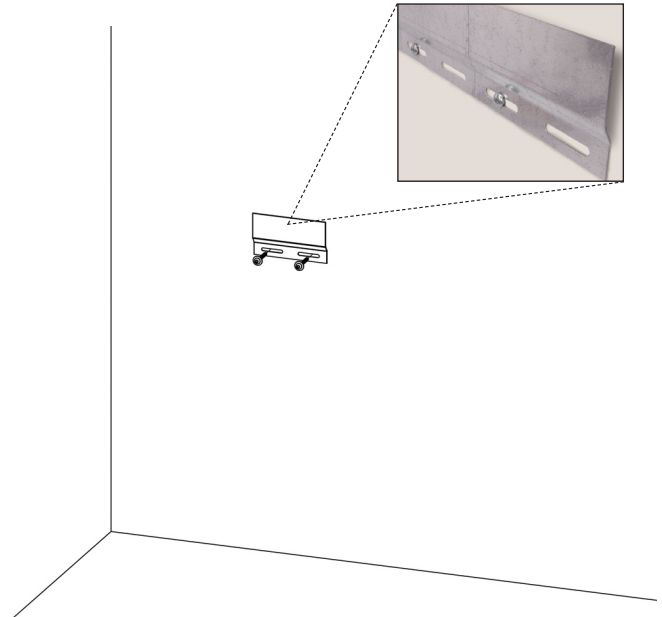
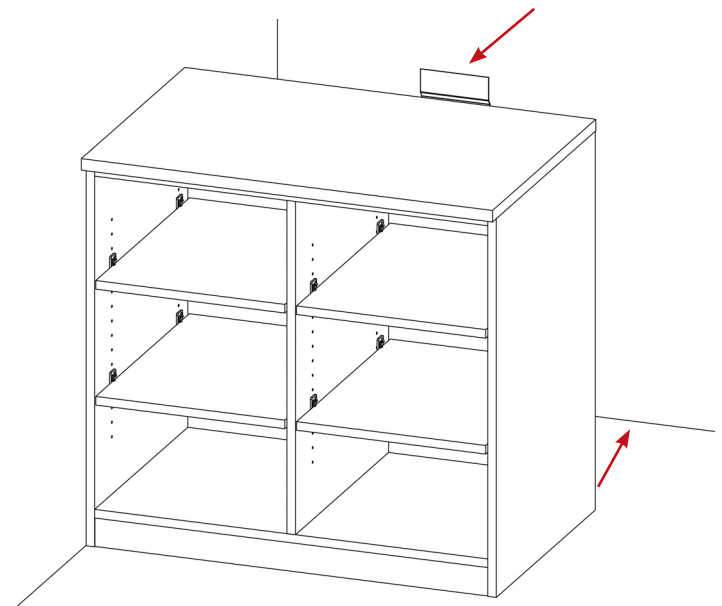

Image above is for illustrative purposes only. You will need to cut bracket accordingly to the size of your cabinet.

Step 2:

- Once mounting bracket is properly fastened to the wall, slide the cabinet against the wall.

Remember this bracket will have a distance of 25.5" from the floor to the center of the screw.



V021522 Version subject to change

Installation Instructions

REplay® Interlock Wall System Kit

Step 3:

- Turn handle from inside the cabinet to engage lock to connect the cabinet to the wall. Image to the right shows you the back of the cabinet and how the latch will hook to the wall bracket.

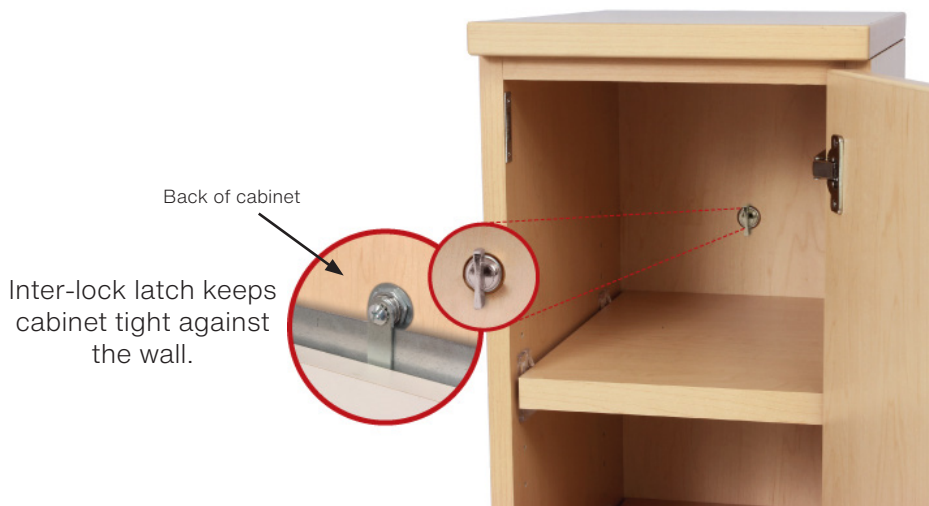
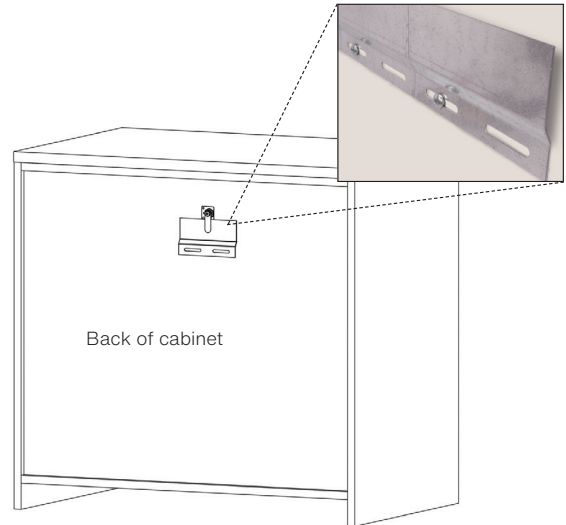
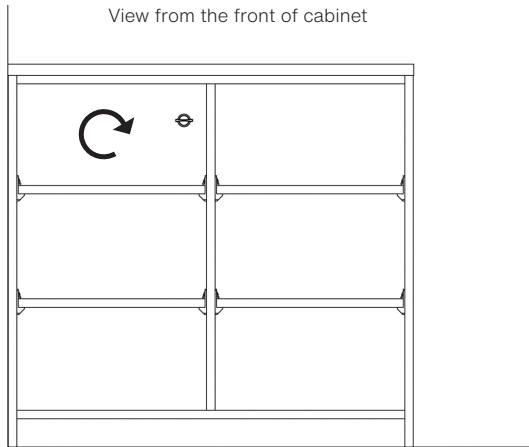

Cabinet shown is for illustrative purposes only.

Part Identifier Key

Part #	Description	Qty.	
04009243	Cabinet clip (inter-lock wall bracket) <i>(Used to connect cabinet to the wall.)</i>	1	