



# Assembly Instructions

## Drafting Table

w/ Drawers on Right

Before you begin, please make sure all parts and proper quantities are included. (See Part Identifier Key) Any parts damaged during shipment must be reported within 24 hours of receipt. To report information regarding damages or if you have any questions, please call 800.242.2303.

### Step 1:

- Lay apron assembly on a protected flat surface with apron side facing up.

### Step 2:

- Insert hanger bolt on one leg through the corner bracket and insert lock washer and hex nut.
- Screw on nut using a 1/2" wrench or 1/2" socket and torque wrench.
- Do NOT tighten all the way.
- Repeat for the other leg.
- The leg with the chamfer must go on the front of the table with chamfered edge facing out.

### Step 3:

- Screw leg levelers into t-nut on bottom of legs.

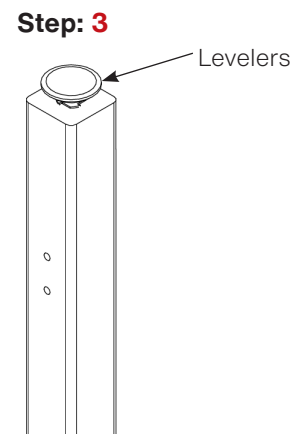
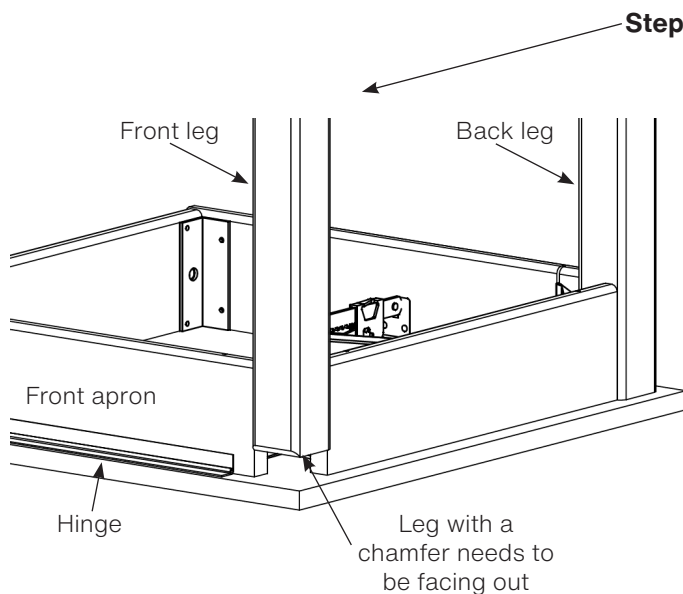
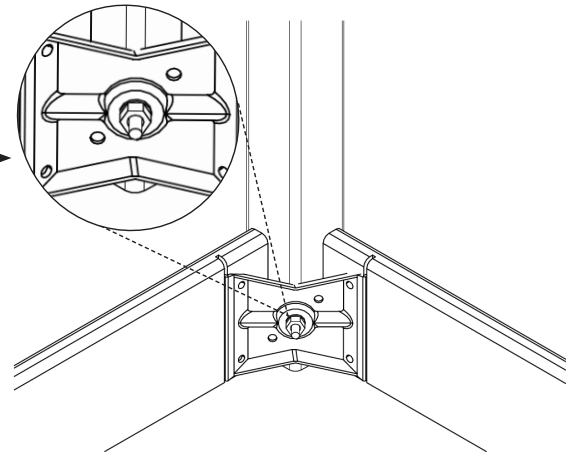
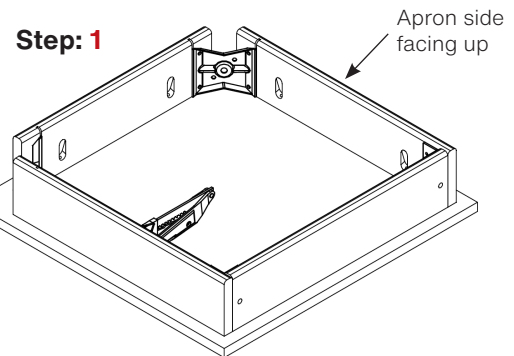

### Tools Required

- 1/2" wrench
- 1/2" socket and torque wrench (optional)
- 4mm wrench

**Step 4:**

- Attach brace between the two legs by inserting confirmats into the legs. Tighten using a 4mm wrench.
- Make sure brace is straight and all confirmats are secure.

**Step 5:**

- Attach stretcher to leg brace with confirmats, tighten with 4mm wrench.
- Go back to **Step 2** and tighten the hanger bolt for each leg using a 1/2" wrench or 1/2" socket and torque wrench, to a minimum of 12ft lbs but not to exceed 17ft lbs.

**Step 6:**

- Take out drawers to attach stretcher from inside the cabinet.
- With someones help, flip apron assembly over onto legs.
- Align holes on stretcher to holes on left side of cabinet.
- Attach the stretcher to the cabinet with corfirmats, tighten with 4mm wrench.

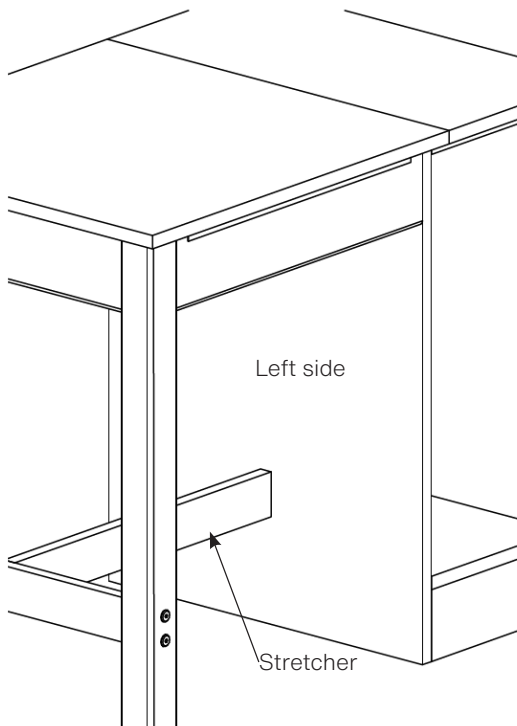
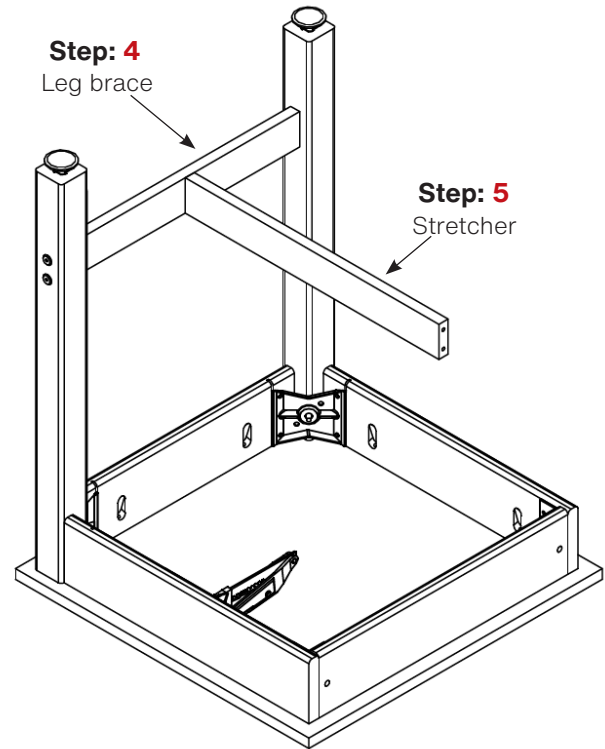

Outside of cabinet

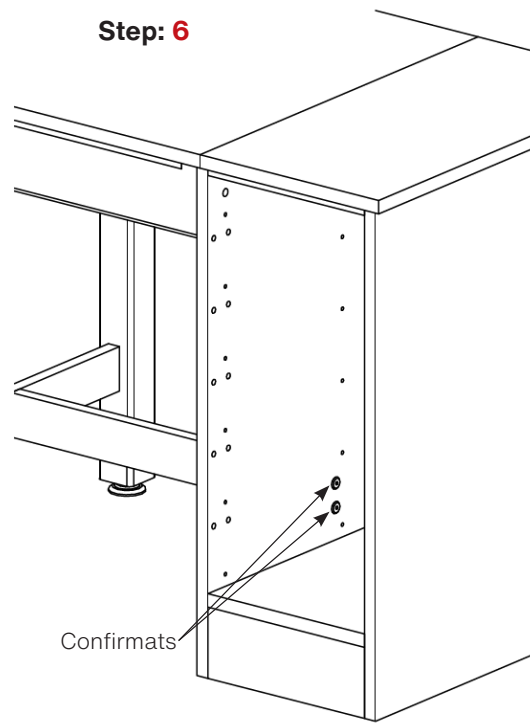

Inside of cabinet

### Step 7:

- Position apron assembly so inner holes of brackets on internal apron are lined up with two holes on left side of cabinet.
- Front apron will be flush with front of cabinet and back apron will be flush with the back of the cabinet.
- Attach apron assembly to left side of cabinet with hardware provided.
- Adjust leg levelers to level apron assembly with cabinet.

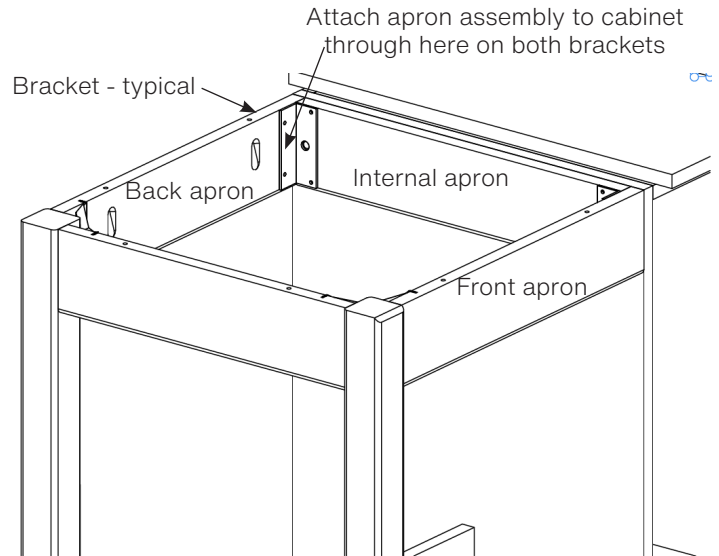

### Step 8:

- Line up pencil ledge on side of adjustable top in desired location.
- Pre-drill holes in top to prevent splitting.
- Screw pencil ledge to top using hardware provided.
- Set your table in place.
- Put drawers back in.

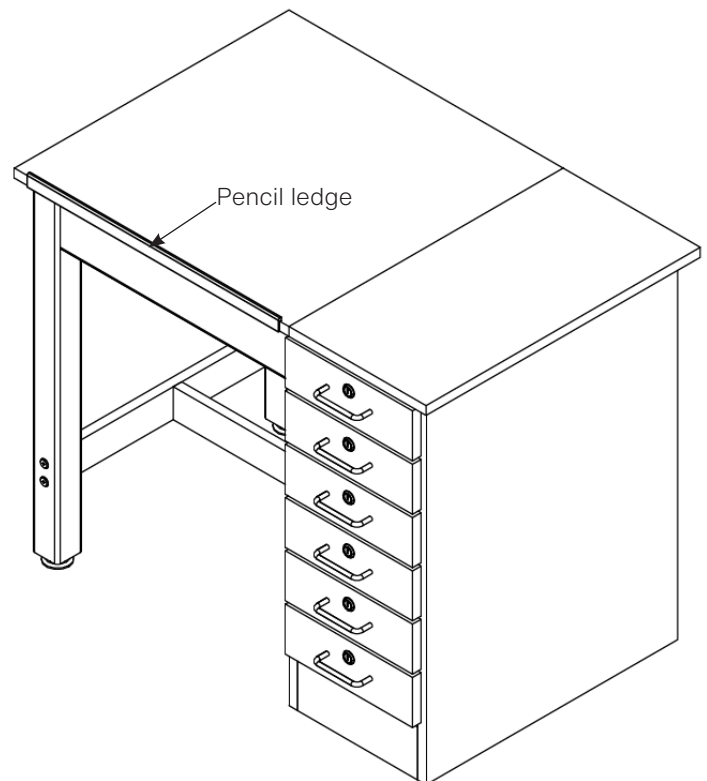

## Part Identifier Key

Items Included	Part #	Part Description	QTY
Top and apron assembly	N/A	Top assembly (factory assembled)	1
Cabinet	N/A	Cabinet - size varies	1
Legs	Varies	Leg, mpl - height varies	2
Leg hardware	520001	Leg hardware kit, 1 leg	2
Leg brace	N/A	Leg brace - size varies	1
Stretcher brace	N/A	Stretcher - 20.75" long	1
Confirmats - legs	227578	Screw, 7mmx90mm, conn, Allen head, black	4
Confirmats - stretcher	228564	Screw, 7mmx90mm, conn, Allen head,black	4
Bolt - Internal apron	231922	Bolt, 3/8-16x1.625 hex head	2
Washer - internal apron	100451	Washer, 5/16" flat zinc plated	2
Pencil ledge	14-0027	Pencil ledge	1
Screws - Pencil ledge	236263	Screws, #6x3/4" truss head, quad black	6